

# KENILWORTH COMBUSTION

## Stranded Gas Combustor

Patent Pending

**PRODUCT FEATURES:**

- Arrives on site pre-assembled and function tested
- SCC/CSA Field Approval ready
- Specifically designed fueltrain for optimizing combustion
- Available in Sweet or Sour Service configurations
- Includes patented Kenilworth Combustion burner
- Designed to prevent freeze off from wet fuel
- Low power consumption
- Small foot print
- No pilings, anchors, or guide wires required
- Skid mounted for easy installation
- Multiple fuel volume processing capabilities available (Oz-PSI pressure supply)
- Kenilworth Velocity Stack Mixer monitors and controls stack temperature, all temps are monitored via BMS to not exceed auto ignition set points of the combustable gases typically found on site:

Methane @ 540C  
 Propane @ 470C  
 H2S @ 260C

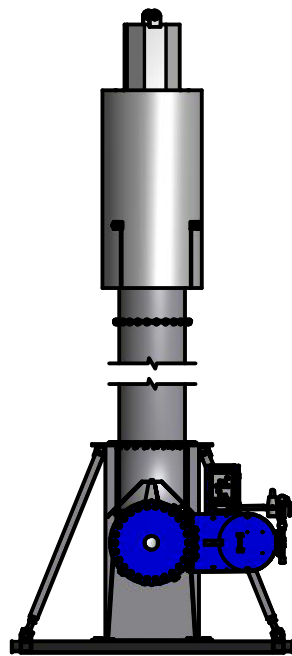

FRONT VIEW

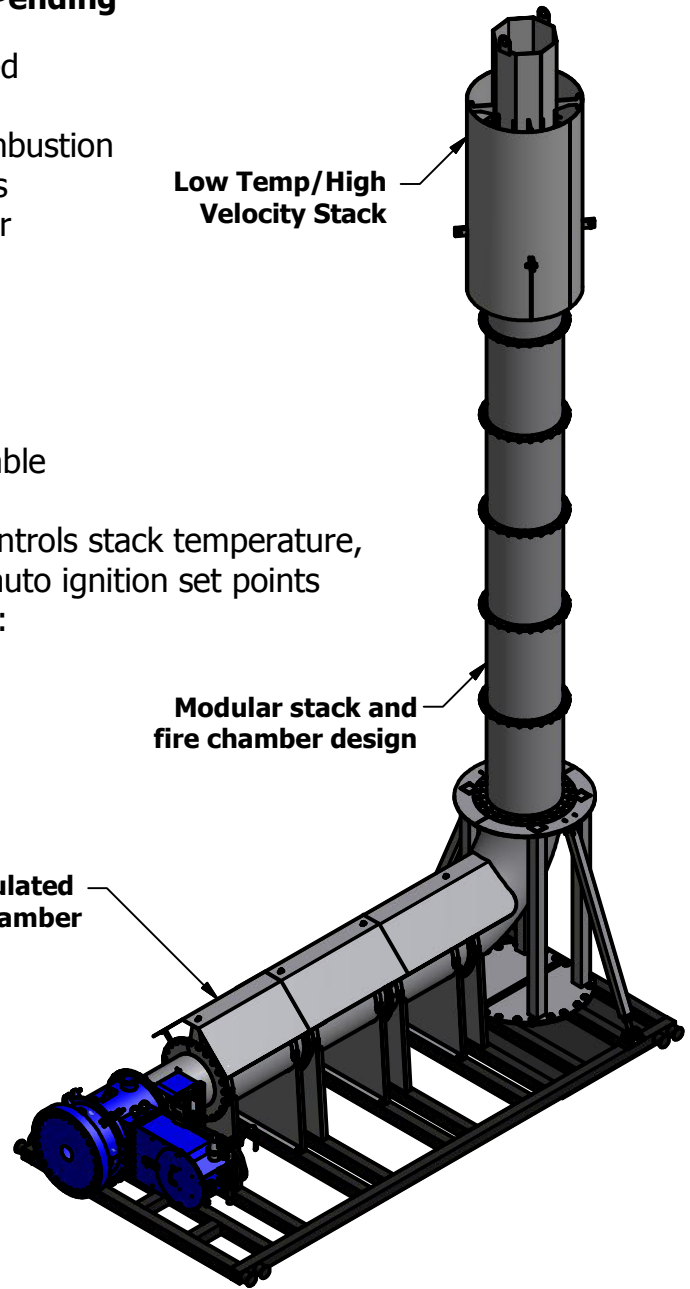

Low Temp/High Velocity Stack

Modular stack and fire chamber design

Fully insulated fire chamber

ADDITIONAL OPTIONS

- SCC/CSA Field Certification
- Pre-installed Heat Trace
- Multiple BMS options

# KENILWORTH COMBUSTION

MODEL NUMBER

Stranded Gas Combustor

Contact info  
[www.kenilworth.ca](http://www.kenilworth.ca)  
 (780) 835-5340  
[info@kenilworth.ca](mailto:info@kenilworth.ca)

SIZE  
**A**

PRODUCT TYPE  
**Stranded Gas**

REV  
**1**

SCALE

SHEET 1 OF 1